

Control of Surface and Concealed Condensation

Madeleine Z. Rousseau

Introduction

Condensation in houses is a controversial and complicated issue. Over the last ten years, it has taken on new dimensions because of the changes in building practice. For example, Canadian houses are better insulated and this affects the temperature regime of the building envelope; outside and inside surfaces of walls are subject to colder and warmer temperatures, respectively. Therefore, the potential for surface condensation inside the house is reduced, while the potential for concealed condensation in the wall and ceiling cavities is increased. Moreover, houses today are more airtight, which often results in higher humidity levels; this in turn may lead to increased surface condensation, particularly on windows. This paper discusses the mechanisms of condensation: how, where and why condensation occurs on walls, windows and basement surfaces, as well as within walls, windows and attics.

Surface Condensation

Surface condensation is the phenomenon by which moisture condenses on visible surfaces. It occurs on surfaces that are at a temperature below the dew point temperature of the inside air. In the wintertime, surface condensation is most common on windows and window frames, over the gypsum board face at or near the stud connection of the walls, on floors and at wall corners.

When moist inside air is cooled, a temperature is reached at which the air becomes saturated with moisture. This is the dew point temperature of the inside air. If the surrounding surfaces continue to cool, the moisture in the air condenses on the surfaces as a liquid or as frost, if the surface temperature falls below freezing. Therefore, three factors are involved in the surface condensation process: the inside air temperature, the indoor humidity level, and the surface temperature. The latter is a function of the outside temperature and the thermal resistance of the assembly. The interaction of these factors is best explained on a [psychrometric chart](#).

Psychrometrics

The [psychrometric chart](#) is used to describe the physical characteristics of air and water vapour over a broad range of temperatures (Figure 1). The vertical scale represents the absolute moisture content, defined as the number of kilograms of moisture per kilogram of dry air. The horizontal scale is the air temperature, scaled from -10 to +55°C. The saturation curve (100% RH curve or dew point curve) shows the maximum amount of moisture that the air can hold at any temperature in this range. The higher the temperature, the more moisture the air can hold. For example, air at 23°C can hold six times as much water vapour as air at -5°C (Figure 2). The other curves are the relative humidity curves, and represent a fraction of the saturation point. The 50% RH curve means that at this curve the air holds half of the amount of moisture it could potentially hold (Figure 3). This chart is often used to calculate the dew point temperature of the inside air; from this one can calculate the

required thermal resistance of an assembly (such as a window) to prevent or avoid condensation on its surface.

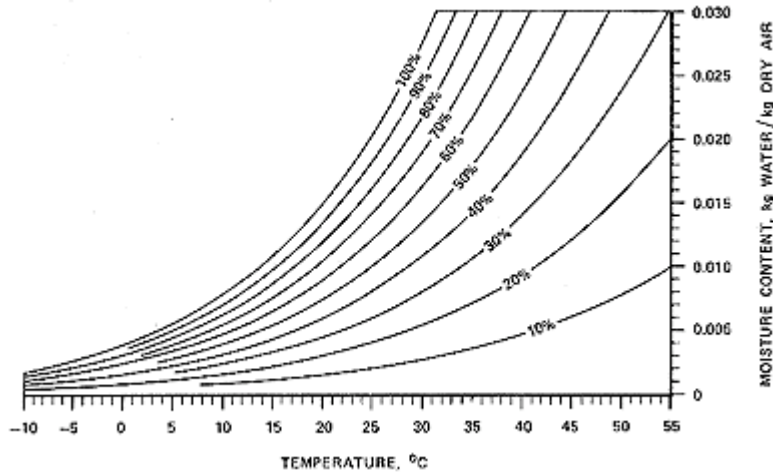

Figure 1

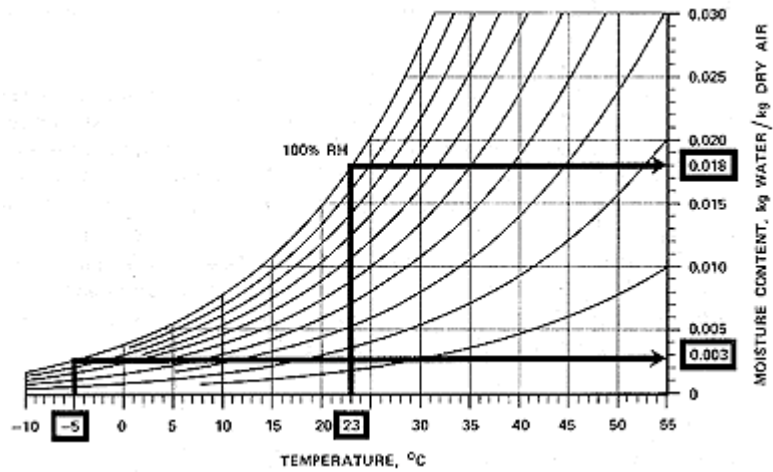

Figure 2

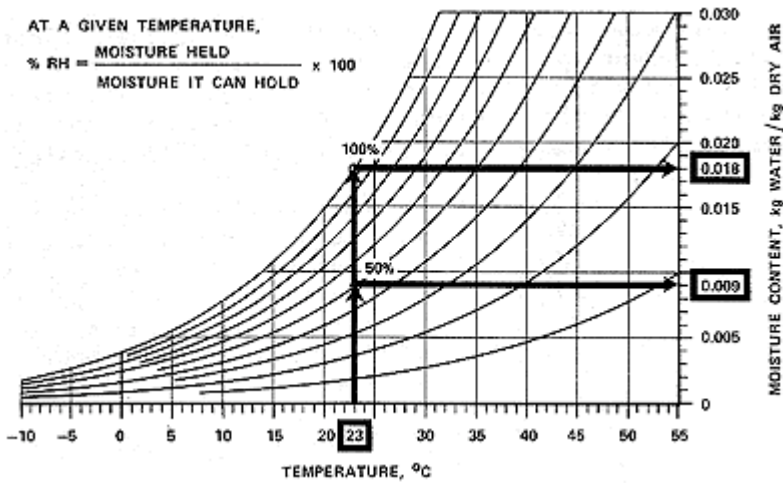

Figure 3

For example, suppose that the inside air in a room is at 23°C and 50% RH; what would be the dew point temperature of the air? First, plot the intersection of the inside air temperature with the measured relative humidity (Figure 4). Second, move horizontally to the left until you intersect the 100% RH curve. Third, plot the intersection downward until it intersects the temperature axis once more, at about 12°C. This is the dew point temperature of the inside air. Therefore, if condensation appears on the surface of window glass, then the temperature of the glass must be below 12°C.

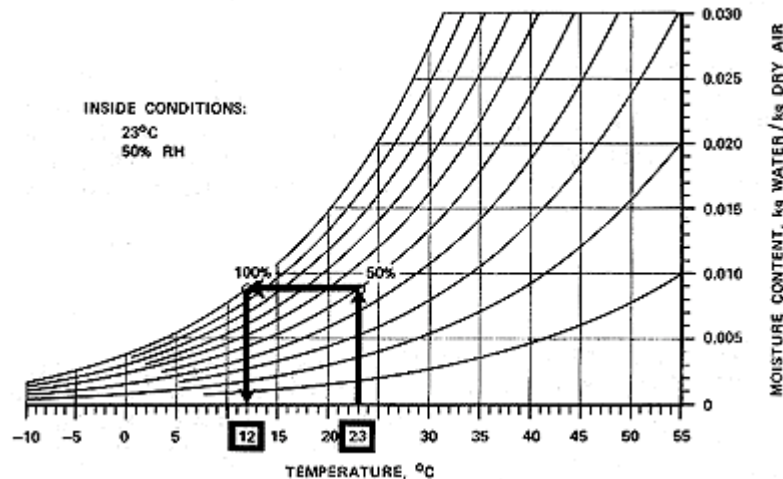

Figure 4

Summer condensation in basements

Condensation may also occur in the summertime on basement floors, especially if the basement space is ventilated. Outside air has a high moisture content during warm weather and the dew point temperature of the air may also be relatively high. Basement floors, which are most often uninsulated, may easily be colder than the dew point of the outside air.

For example, it can be shown on the [psychrometric chart](#) (Figure 5) that if the outside air is at 25°C and 65% RH, the dew point temperature of the air is 18°C. Condensation will occur on the concrete floor surface or concrete foundation wall if the surface temperature is below the dew point temperature.

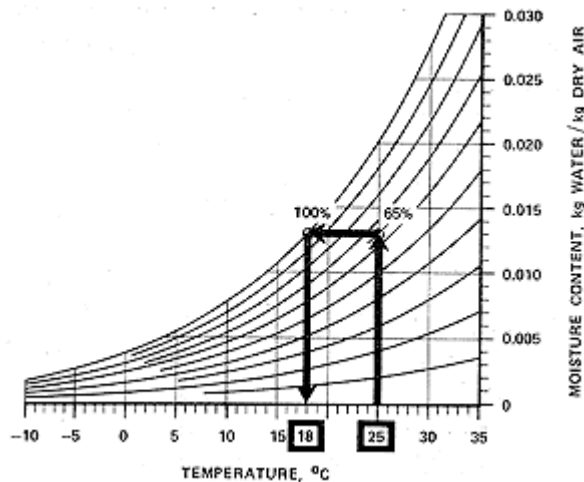

Figure 5

Surface condensation is caused either by a low surface temperature or a high humidity level in the air. The solution is either to increase the thermal resistance of an assembly to increase its surface temperature, or to reduce the humidity level in the house. The thermal resistance of a window may be increased by adding a pane or two; the humidity level in the house may be reduced by increasing the ventilation rate during winter or reducing the number of moisture sources.

If condensation occurs on basement walls during the summer or winter, it may be most practical to insulate the basement foundation wall so as to prevent the warm humid air from reaching the cold concrete. This will also reduce energy loss through the foundation walls. However, if condensation occurs on the basement floor during summer, it may be more practical to dehumidify the basement air.

Concealed Condensation

Damage such as the rotting of exterior sheathing or structural members, the buckling of cladding, spalling and efflorescence on brick and concrete walls, peeling of exterior paint, and condensation between window panes, is mostly due to the presence of water in a cavity. The occurrence of concealed condensation requires three conditions: a moderately high humidity level, moisture movement into a cavity, and a surface which is below the dew point temperature of the inside air. The movement of moisture into a cavity may occur by diffusion through the materials of the wall or ceiling, or by air leakage through holes and cracks presenting an unobstructed path from inside to outside.

Diffusion

Diffusion is the movement of moisture through a building material from a location of high moisture content towards a location of lower moisture content. The diffusion rate is a function of the permeability of the material to water vapour (Figure 6). It is almost always outward in winter. Movement of moisture by diffusion occurs without any flow of air and is a very slow process.

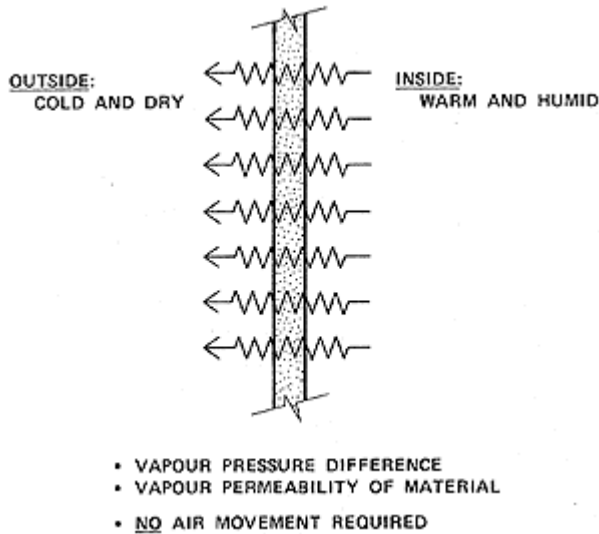

Figure 6

Water vapour diffusion may be compared to water seeping through the surface of a cardboard container (Figure 7). Water permeates slowly and uniformly through the cardboard container surface. The solution is to use a much less porous material, such as plastic or metal. This approach is also used in building construction to control diffusion of water vapour through walls and roofs.

CAUSE: THE MATERIAL



SOLUTION: THE SELECTION OF ANOTHER MATERIAL



Figure 7

Since it is necessary to maintain indoor humidity at a high enough level for health and comfort, there will inevitably be a humidity difference causing a migration of water vapour from inside the house to the outside. The simplest way to reduce or control the diffusion rate of water vapour into walls and roofs is to choose materials which have a low permeability to water vapour transfer. This material should be placed on the warm side of the insulation, where the water is still in the vapour

phase. The material is called a vapour barrier or a vapour retarder.

Examples of vapour barriers are polyethylene film and aluminum foil; there are also several types of paints that could be used as vapour retarders. Their importance in an assembly is well recognized and their required properties are known. The installation of a vapour barrier in a wall assembly practically eliminates the potential for condensation to occur in cavities by diffusion only.

Air leakage

Moist warm air can also flow to the cavity of a wall or ceiling by air exfiltration. Air leakage through an assembly of materials occurs when there are cracks and holes within the assembly and an air pressure difference across the hole or crack. The air leakage rate is a function of the number and size of the holes and the air pressure difference acting across these openings. Air can leak around windows and doors, at chimneys, through holes for electrical wires, and at electrical outlets, just to name a few places.

Using the previous example of a container filled with water, air leakage is similar in principle to a water leak (Figure 8). Whether the material is cardboard or metal will be irrelevant if the container has a sizeable hole in it. The solution is to seal all leaks and holes. Similarly, a building enclosure must be devoid of all leaks, cracks or openings, if air leakage is to be controlled.

CAUSE: THE ASSEMBLY

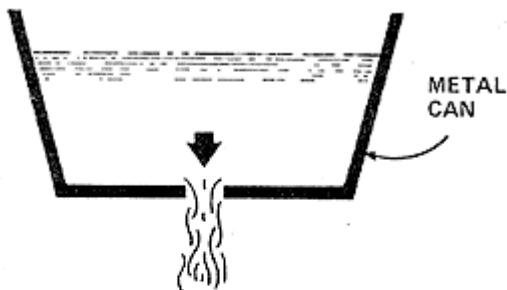

SOLUTION: THE DESIGN OF THE ASSEMBLY



Figure 8

Moisture transport into cavities - diffusion versus air leakage

The potential transport of water vapour into cavities by diffusion and air leakage can be compared by an example. Given a square metre of gypsum board with two coats

of enamel paint, exposed to 22°C and 40% RH on the warm side and a mean daily outside winter condition for Ottawa on the other side (Figure 9), 1/3 of a litre of water vapour would diffuse over a five-month period.

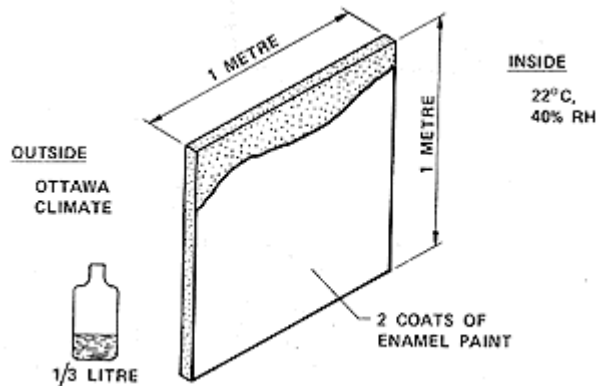

Figure 9 Diffusion - Over one heating season...

Through a four centimeter square opening, it is possible to pass about 30 litres of water vapour to the outside if a ten pascal air pressure difference exists across the gypsum board (Figure 10). The air leakage process can transport 100 times as much water as that which is transported by diffusion through the one metre square board. Therefore, air leakage through the enclosure is the major mechanism of moisture transfer into cavities.

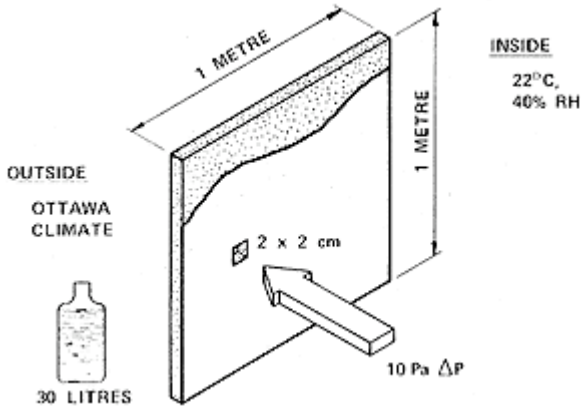

Figure 10 Air leakage - Over one heating season...

Control of Air Leakage

Air leakage may be considered as either air infiltration or air exfiltration. Since concealed condensation is due primarily to air exfiltration, the emphasis here will be on air exfiltration control. There are two ways to control air exfiltration: the first is to control the direction of air flow and the second is to minimize the number and size of holes. To induce an inward flow of air, the indoor air pressure must be rendered slightly negative with respect to the outside. This will prevent concealed condensation, but this solution is not without its problems. It may also induce an undesirable air infiltration through the walls and ceilings, causing surface

condensation (Figure 11), cooling of indoor air and subsequent loss of comfort, low humidity level, and increased heating costs. So, there is only one viable option: to make the building envelope airtight and free of all air leakage.

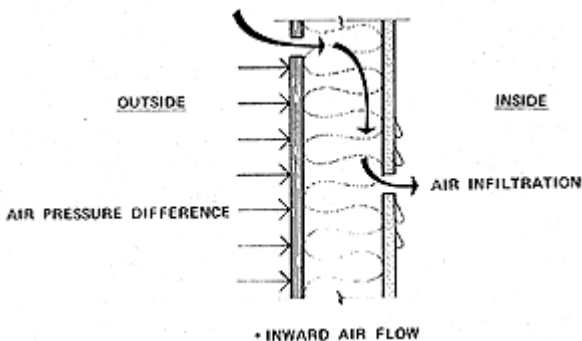

Figure 11

Airtight materials and systems

The system of building materials that will act to stop air movement must also resist the peak air pressure difference that may be induced from a combination of wind load, stack effect and ventilation equipment. Thus, the air leakage control system must also be structural, and rigid, if possible, or if flexible, be supported on both sides. The system must be impermeable to air (not water vapour) and it must form a continuous assembly, designed and built to stay continuous over the life of the building.

Gypsum board, exterior sheathings (e.g. plywood, waferboard), and some types of insulating boards may have the characteristics required. At the present time, no material or assembly of materials is tested for structural adequacy with respect to airtightness and air permeability. However, even without the necessary numbers, it is possible to design and construct a functional airtight assembly within the envelope of a house.

A plastic film that is a good vapour barrier may not be the most appropriate material for an air barrier. A rigid material impermeable to air, like an insulating exterior sheathing, must be mechanically fastened in place, otherwise it can detach and fall into a cavity.

Returning to the example of the leaky container, (Figure 12) merely plugging a hole does not ensure that it will be leak-proof. The plug in the container may only be a short term solution. What is required is a structural support capable of withstanding the pressures that may be exerted on the patch or repair plug.

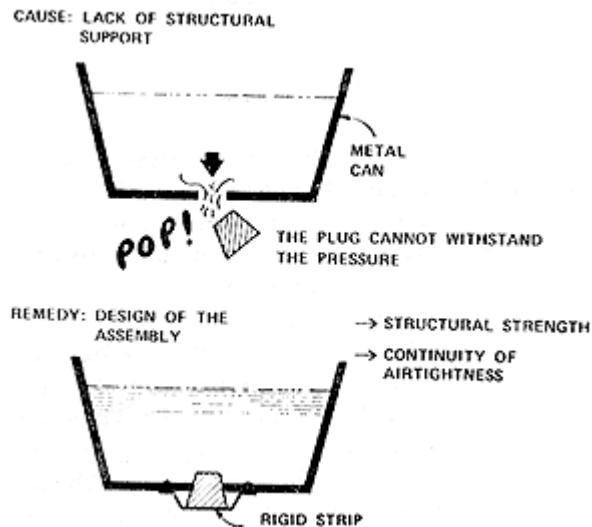

Figure 12

Depending upon the materials chosen and the design of the wall or roof, there are a number of alternative methods to ensure airtightness and its continuity over the building enclosure. The air sealing method selected should be carried out consistently and throughout the whole of the building enclosure. This means that not only walls and ceilings must follow the principle but it must be carried out consistently at floor-wall, wall-and-partition, and wall-and-ceiling junctions. It may also be necessary to extend an airtightness assembly to below-grade connections to reduce moisture entry by air seeping in through cracks and joints, as mentioned in the previous paper.

Wall Air Leakage Problems

Cladding deterioration, efflorescence on brick and rotting of wood members may be due to rain penetration or concealed condensation; either way, air leakage is a major contributing factor. A wall that has a good vapour barrier but no air barrier, may have a localized spot of concealed condensation. Because walls are made up of many layers of materials with cavities between, the flow of air will usually require that there be an entrance to and an exit from the cavity. Thus if air leakage is outward (i.e. exfiltration) the air will follow a particular path from its entry point in the wall to its exit point in the exterior cladding. Condensation of moisture from the air is likely to occur near the end of the path, on a surface that is at a temperature below the dew point temperature of the inside air (Figure 13). The openings are often the large gaps left between exterior sheathing boards or between the window frame and the rough opening, even though it is filled with fibreglass.

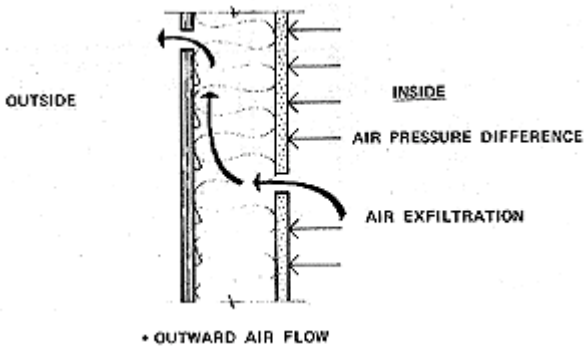

Figure 13

Materials such as exterior sheathings or brick cladding can store water for a while, until the right climatic conditions, such as a sunny day, cause the water to migrate towards the outside. Condensation on a porous surface increases the moisture content of the material. Efflorescence on a brick cladding is due to the migration of water to the outside. As the water migrates to the outside it brings with it calcium salts present in the mortar to deposit them on the surface when the water evaporates. The question is, "how does moisture find its way to the backside of the brick siding?" It may be by rain penetration, but more likely it is inside moisture transported by air leakage through the wall during winter.

Whether the cause is rain penetration or air exfiltration, the solution is to have an air barrier system somewhere within the building enclosure. In fact, an air barrier can be located almost anywhere within the building assembly to control throughflow of air.* If either the inside or the outside skin of a wall is airtight, then the throughflow of air should be under control. Thus, the primary reason for the deposition of moisture in a cavity has been effectively eliminated.

* The apparent contradiction with other recommendations arises from the vagueness of the distinction between the function of a vapour barrier (which is well defined) and that of an air barrier (which is not yet adequately defined).

Air Barrier Inside

When the interior finish is intended to be the wall air barrier (Figure 14), the critical point becomes its continuity over the enclosure. All connections with floors, partition walls, electrical outlets and switches must be made structurally airtight. Airtight boxes should be built around electrical outlets to ensure continuity of the air barrier. The air barrier on the warm side of the enclosure has the advantage of being exposed to relatively stable thermal conditions, but it can be also subjected to numerous penetrations as it is the interior finish. It has a further advantage in that if it is visible, it is also serviceable.

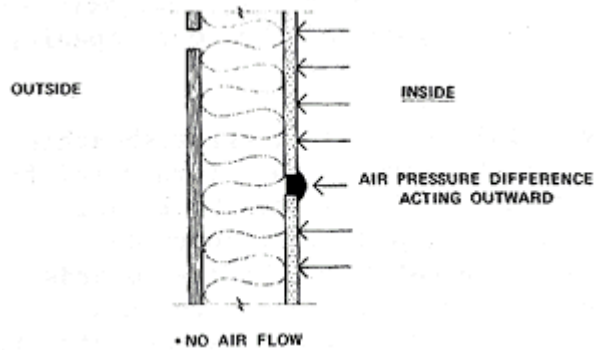

Figure 14

Air barrier outside

When the exterior sheathing is intended to be the air barrier element of the wall (Figure 15), its continuity over the wall and around corners is much easier to achieve from a construction point of view. Most outside structural framing presents a continuous uninterrupted surface over floor connections, partition walls, and exterior corners. It also removes the concern with penetrations of electrical outlet boxes through interior finishes. The materials used for this purpose should be rigid, well supported, air impermeable and fastened directly to the structure. They must be made continuous over the whole wall with appropriate joint connecting materials, and continuous with the ceiling assembly and foundation wall. The materials should have a high water vapour permeability and a low air permeability, for example, gypsum board or dense fibreboard. Depending on the water vapour permeability of the air barrier, it may be necessary to install on the warm side of the insulation a vapour barrier that is considerably less permeable than the sheathing material used for airtightness on the outside of the wall.

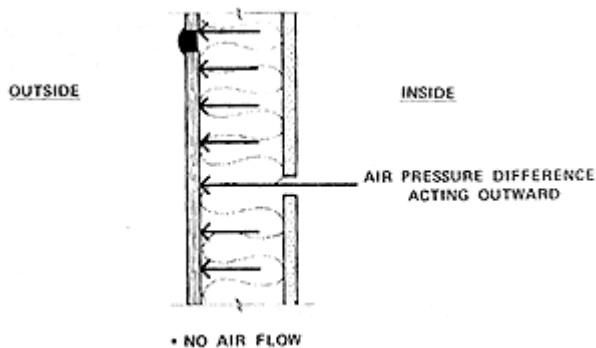

Figure 15

In brief there are many ways to install an air barrier in a wall, in order to avoid serious localized moisture damage in wall cavities. Only one surface of a wall needs to be structurally airtight; whether it be inside or outside is not relevant to the control of the throughflow of air. However there must be a good quality vapour barrier on the warm side of the assembly.

Condensation in Attics

Attics may be more prone to harbour condensation because the air pressure difference across a ceiling is often positive and this induces an air exfiltration pattern through cracks and holes.

Moisture transport in an attic is similar to that in other cavities; air leakage is usually the major means of supplying the attic with moisture. When the temperature of the outside sheathing of the roof is below the dew point temperature of the attic air, condensation occurs on its inner surface. The moisture content of the wood increases slowly and the sheathing may deteriorate in a few years.

The location of condensation in an attic is a function of the leakage path from the inlet holes in the ceiling to the outlet holes in the roof. Consider the following example; a bathroom fan is ducted through the attic to exhaust moist stale air through the roof. Often, condensation occurs inside the duct, and water may drip back down into the bathroom. The occupants will then disconnect the duct through the roof (Figure 16) and leave the duct or piping lying on the insulation. A significant amount of moisture is then drawn into the attic by the fan: if there is a ridge vent on the roof, this becomes an important moisture outlet.

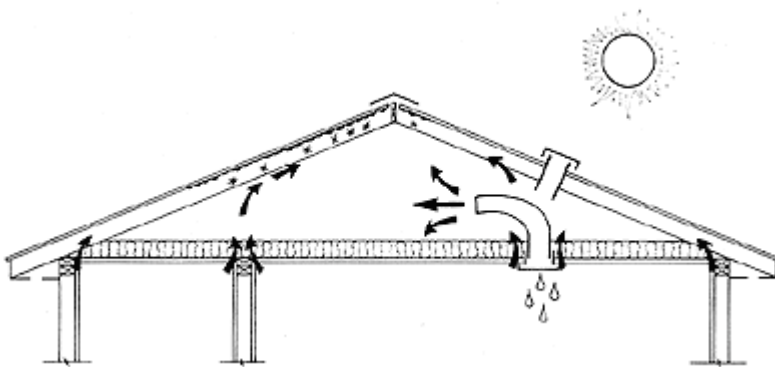

Figure 16

The cold air in the attic cannot absorb much moisture because the outside air is often close to saturation. The building materials on the path of the air stream to the outside may absorb part of the moisture and the condensation pattern is related to this path.

The orientation of the roof also has an effect on the potential for concealed condensation damage. A southern pitch will dry out more quickly during the day than a pitch on a northern exposure. All these factors acting together make every pattern of attic condensation almost unique.

The best way to control an attic condensation problem is to tighten the ceiling and the walls. For example in row houses, moisture can get into attic cavities by seeping through a common concrete block partition wall. In this context, it is of prime importance to properly air seal all paths into the attic. These are not always obvious.

Summary

Surface condensation is either due to a high humidity level or a low surface temperature. It can be controlled by acting on the moisture gains and the ventilation to lower the relative humidity, or by increasing the surface temperatures of those components which exhibit surface condensation.

Concealed condensation is more complex than surface condensation. Moisture can be transported into cavities by diffusion or by air leakage. It has been recognized since the early 60's that air leakage is the major cause of moisture problems in wall and roof enclosures or cavities. Attention to vapour diffusion control has been thorough, but air leakage control is not yet fully understood. It is necessary to have both a vapour barrier and an air barrier within the building envelope to control the diffusion rate of moisture as well as to stop or reduce air leakage through the cavities.

The air barrier has properties which are quite different from those of a vapour barrier. A vapour barrier deals with a difference in water vapour pressure while the air barrier must deal with an air pressure difference (with or without humidity), and resist the forces caused by wind, ventilation and stack effect. A vapour barrier is required in a wall or roof assembly but it is not sufficient to eliminate the moisture problems from cavities.

The precise characteristics of an air barrier are not completely defined as yet, but it must be structurally supported, rigid if possible, or if a flexible membrane, then supported on both sides. Needless to say, the whole assembly must have a low air permeability and be continuous throughout the building enclosure.

This article was published as part of the technical documentation produced for Building Science Insight '83, "Humidity, Condensation and Ventilation in Houses", a series of seminars presented in major cities across Canada in 1983.

