

Designing Exterior Walls According to the Rainscreen Principle

[Construction Technology Update](#) No. 34, Dec. 1999

by **W.C. Brown, G.A. Chown, G.F. Poirier and M.Z. Rousseau**

This CTU discusses the application of the rainscreen principle to the design of exterior walls, building on the concepts presented in [Construction Technology Updates No. 9](#) and [No. 17](#).

The rainscreen principle described in [Construction Technology Update No. 9](#) provides a design approach for controlling rain penetration into exterior walls.¹ This approach is founded on the premise that multiple-element protection is necessary in most situations to achieve effective control, by means of

1. a first line of defence that minimizes rainwater passage into the wall by minimizing the number and size of holes and managing the driving forces acting on the wall;
2. a second line of defence that intercepts all water that gets past the first line of defence and effectively dissipates it to the exterior.

This CTU discusses the design characteristics of the first and second lines of defence, taking into account the environmental conditions prevailing at the site as well as the moisture management strategy for the wall.

While the focus of this Update is on the role of the first and second lines of defence in controlling rain penetration, it is important to bear in mind that the air barrier system also plays an essential role in this regard by reducing the air pressure difference across the building envelope. (See [Construction Technology Update No. 17](#).²)

Sources of Climate Data

The National Building Code of Canada 1995 provides climate data such as maximum 15-minute and 24-hour rainfall, and total annual precipitation.³ Climate normals for Canadian locations are available at http://www.climate.weatheroffice.ec.gc.ca/Welcome_e.html. Additional information, such as total annual rainfall and number of days with measurable rain, is also provided. Driving rain wind pressure (DRWP) values are tabulated in CSA Special Publication A440.1.⁴ (DRWP is the maximum 'instantaneous' wind pressure, coincident with rainfall, that is likely to be exceeded once in five years or once in 10 years). Annual driving rain index (ADRI) values are provided in CSA Standard A370.⁵ (ADRI is the product of annual rainfall and mean annual wind speed.)

Environmental Conditions

Moisture loads, such as precipitation or water vapour, and the forces that drive moisture through exterior walls are defined by both the exterior and interior

environments (see "[Overall Moisture Management](#)"). The relative severity of environmental conditions must be understood since a wall assembly that is trouble-free in one area of the country may not perform adequately in another. The intensity, duration and frequency of precipitation determine the moisture load. Wind affects the deposition of precipitation on a building, while building height and shape affect the pattern of wetting and redistribution. The moisture load on a particular element of the facade also depends largely on how the exterior features, such as balconies or mullions, collect and redistribute rainwater. Air temperature, relative humidity and solar heating all influence the drying rate of the wall assembly, and hence, the moisture load on the wall elements.

The First Line of Defence

The cladding provides the first line of defence in the rainscreen design, and as such bears the full brunt of the weather. The following objectives should be addressed when designing the first line of defence:

1. Reduce the moisture load on the cladding
2. Minimize the number and size of holes in the cladding
3. Manage the driving forces across the cladding.

Achieving these objectives will minimize the quantity of water that reaches the second line of defence. As a general rule, the designer should aim for perfection in the first line of defence, since the wall assembly when built is likely to be less than perfect for various reasons, including the challenges of building it as stipulated, the quality of the workmanship, differential building movement and the deterioration of materials over time.

Reducing Moisture Loads

Water can be deposited on cladding by the wind, by drainage from sloped roofs or projecting horizontal surfaces such as windowsills (in the form of rainwater and snowmelt), and by splashing from horizontal surfaces, including the ground.

Some issues and approaches to consider in reducing moisture loads are as follows:

- Roof overhangs, cornices and balconies will reduce moisture loading on walls below as long as they direct the water away from the wall.⁷ Their effectiveness is influenced by depth of projection, building height and local DRWP (Figure 1). Overhangs always provide some benefit, even in areas of high DRWP. Eavestroughing can be used in combination with an overhang to reduce the moisture load.
- Impermeable surfaces and architectural features may result in localized concentrations of water. Lower storeys must be designed to handle these larger than normal volumes of water flowing from upper storeys.
- Integral sills on windows and drip edges on flashings are effective (Figure 2). A projection of 10 mm beyond the face of the cladding with an appropriate drip edge will direct water away from a wall under no-wind conditions; a

projection of 25 mm may be required to allow for typical construction practices.

- Vertical projections such as curtain wall mullions or window jambs will act as vertical dams under windy conditions and accumulate water at their windward edge.⁸ This possibility must be addressed in the design.

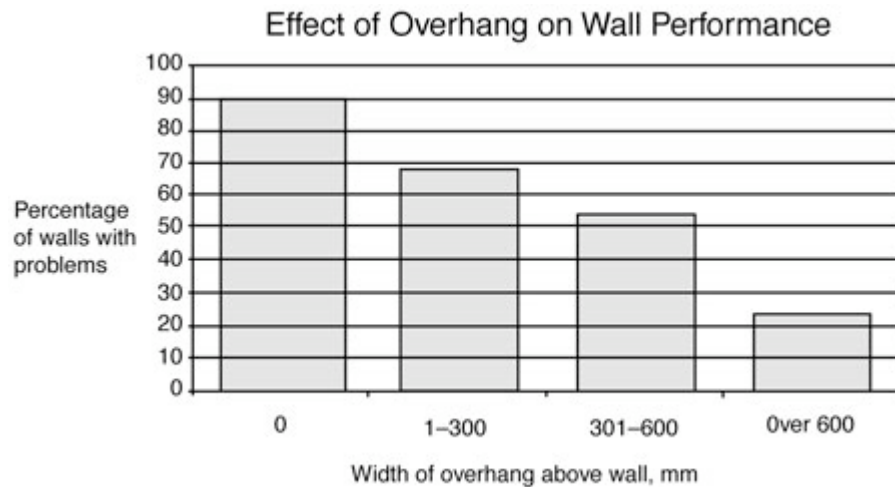

Figure 1. Overhangs were demonstrated to be very effective in the lower mainland of British Columbia.⁶



Figure 2. Example of localized wetting as a consequence of ineffective window-seal detail

Minimizing the Number and Size of Holes

Cladding is constructed of multiple elements that are joined together and that interface with other facade components. Water can penetrate permeable materials and joints between cladding elements. It can also enter at junctions with doors and

windows, service penetrations, and adjacent building envelope systems (for example, where a brick wall meets a metal and glass curtain wall, or where a roof meets a wall). To reduce the load on the second line of defence, the number of holes at joints and junctions should be minimized, and holes (e.g., for drainage and venting) should be limited to those necessary to meet the design intent.

Materials

Permeable cladding materials, e.g., brick, wood and stucco, absorb water due to capillary suction, while impermeable materials, e.g., glass, vinyl and metals, do not. However, the flow rate due to capillary suction is slower than through holes found at the joints of impermeable materials. So, while permeable claddings can offer a short-term buffer against moisture transport through the first line of defence, it is important to bear in mind that water will be stored in the (cladding) material long after the rain has stopped. Therefore, the design of a wall with a permeable cladding must address the issue of how to safely dissipate this stored water.

Joints

The use of cladding constructed of large, impermeable elements, e.g., sheet metal panels or metal and glass in curtain walls, minimizes the length of joint and the number of holes. There will be a greater joint length, and more holes, if smaller, impermeable elements, e.g., vinyl siding or cut stone, are used. In any event, all joints must be considered in the design. Sealants and gaskets can reduce holes at joints provided they are designed and installed to accommodate movement in the joint.⁹ Locked or lapped seams can also minimize holes at joints (e.g., a 150-mm overlap between lengths of vinyl siding works well).

When permeable materials with mortar joints, e.g., brick, are used, the joints must be designed to limit the transfer of liquid water (from outside to inside).¹⁰ Small cracks at the masonry/mortar interface can be a significant entry point for water.

Junctions and components

The junctions between exterior walls and other building components must be designed according to the rainscreen principle, maintaining the continuity between the building envelope systems and the various components — that is, the junctions must be designed with a first and second line of defence.⁶ Windows and doors may permit some rainwater into walls while still meeting the requirements for rain penetration stipulated by applicable standards. Electrical and mechanical penetrations must be sealed on the exterior, preferably with a gasket to minimize the hole created by the penetration.

Managing Forces

The forces that drive water through holes in the cladding are gravity, air pressure difference, capillarity, surface tension and, in the case of raindrops, kinetic energy. Design approaches to control these forces are discussed in Table 1.

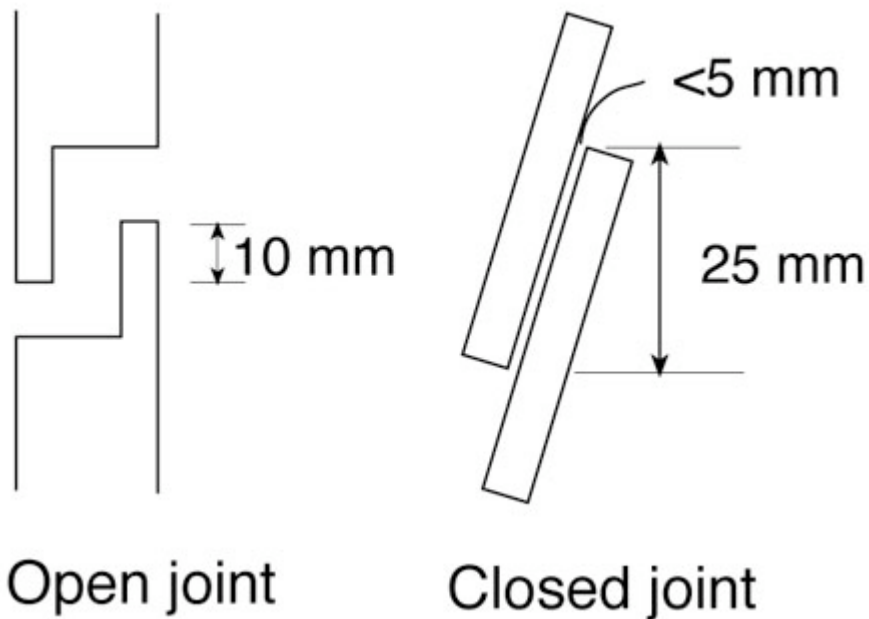

Figure 3. Joint details to control transfer by gravity and capillarity

Table 1. Design approaches for managing forces that drive water through the cladding

Force Type of interaction with rain	Detailing tips
Gravity Moves rainwater down the face of the cladding and into sloped openings (e.g., holes, cracks, and flashing) encountered on the way down	<ul style="list-style-type: none"> ▪ Manage gravity-driven flow at open horizontal joints with a minimum overlap of 10 mm (Figure 3). Overlap in shingle fashion. Avoid reverse laps (where lower element overlaps upper element), as they channel water into the wall. ▪ Provide drainage holes for all horizontal surfaces that can act as troughs. ▪ Provide a minimum slope of 2% on 'horizontal' surfaces to prevent flow to the interior. [The CAN/CSA A440 Standard requires a slope of 8° (14%) for wood windowsills.] ▪ Provide gaskets or sealants for closed vertical joints within a two-stage joint.⁹ ▪ Provide shielding for open joints.

<p>Capillarity (capillary suction) Draws water into permeable materials and small openings (e.g., cracks, joints and junctions)</p>	<ul style="list-style-type: none"> ▪ Shingle lap horizontal joints by at least 25 mm to eliminate water passage, since joints that are less than 5 mm wide support capillarity (Figure 3). ▪ Ensure that drainage and venting holes are at least 10 mm wide to avoid bridging by water. ▪ Choose materials with properties that minimize water absorption or that have greater thickness in order to delay water transport. For example, 20-mm-thick stucco that is subject to continuous wetting will saturate in two days. Therefore, if the building location often experiences rain for this long, change the material or shield the wall with an overhang or other such device.
<p>Air pressure difference Drives rainwater in the direction of lower air pressure</p>	<ul style="list-style-type: none"> ▪ Achieve some degree of pressure equalization across the cladding, its joints and junctions. (Air pressure difference across the cladding is a function of the effectiveness of the air barrier system, the size of the venting in the cladding, the volume of the air chamber between the cladding and the air barrier, and the stiffness of the chamber. Design considerations are discussed in CTU #17.²)
<p>Surface tension Causes water to cling to the underside of horizontal, or nearly horizontal, surfaces</p>	<ul style="list-style-type: none"> ▪ Incorporate a drip in the underside of projecting horizontal surfaces such as windowsills, balcony floors or soffits. ▪ Put a drip edge on flashing.
<p>Kinetic energy of raindrops Propels raindrops into unprotected holes</p>	<ul style="list-style-type: none"> ▪ Shield openings from direct rain entry with overlapping materials, sealant, or preformed gaskets or deflectors.

Second Line of Defence

The amount of water the second line of defence must be able to handle depends on the performance of the first line of defence. The designer should assume that the first line of defence will not intercept all rainwater, since imperfections can be introduced during construction as well as during the service life of the building, e.g., aging of seals. Traditionally, a drained and vented cavity has provided the second line of defence, but today variants on this approach are more common. The design objectives, however, remain the same:

1. To intercept all water that passes through the first line of defence;
2. To dissipate this water effectively to the exterior.

Intercepting Water

Water flows through the first line of defence as either free water (under gravity, pressure difference or kinetic energy) through holes or as bound water (under capillary suction or surface tension) through permeable materials, e.g., stucco, wood or brick veneer, and joints and junctions. The second line of defence must be designed to manage both.

Free water

Free water should be intercepted with a water-resistant assembly. There are two ways to achieve this: 1) a cavity with an inner boundary that sheds water (Figure 4 (a)) or 2) a waterproof membrane (Figure 4 (c)). The latter approach is especially important for assemblies in which the cavity is almost non-existent and the free drainage of water restricted. In residential construction, an effective water-resistant assembly is provided by a cavity whose interior is finished with a breather-type sheathing membrane, e.g., asphalt-impregnated paper or polymeric membrane.¹¹ When impermeable siding, e.g., vinyl or metal, with intermittent cavities behind each element is used (see Figure 4 (b)), full-storey-height cavities are not necessary; however, the inner boundary must be continuous and be made of a material that provides sufficient resistance to the passage of free water.

Closed-cell foam insulating sheathing, e.g., extruded polystyrene (XEPS) or foil-covered polyurethane, can provide an effective inner boundary if the joints are detailed to shed, not transport, water. Modified bituminous membranes have been used successfully on walls where a combination of waterproofing and airtightness is required.

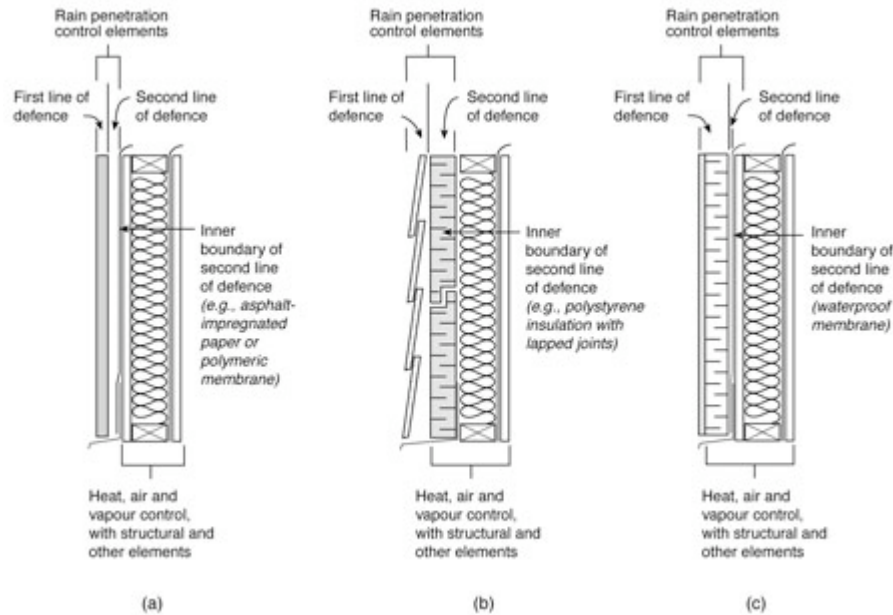

Figure 4. Water-resistant assemblies

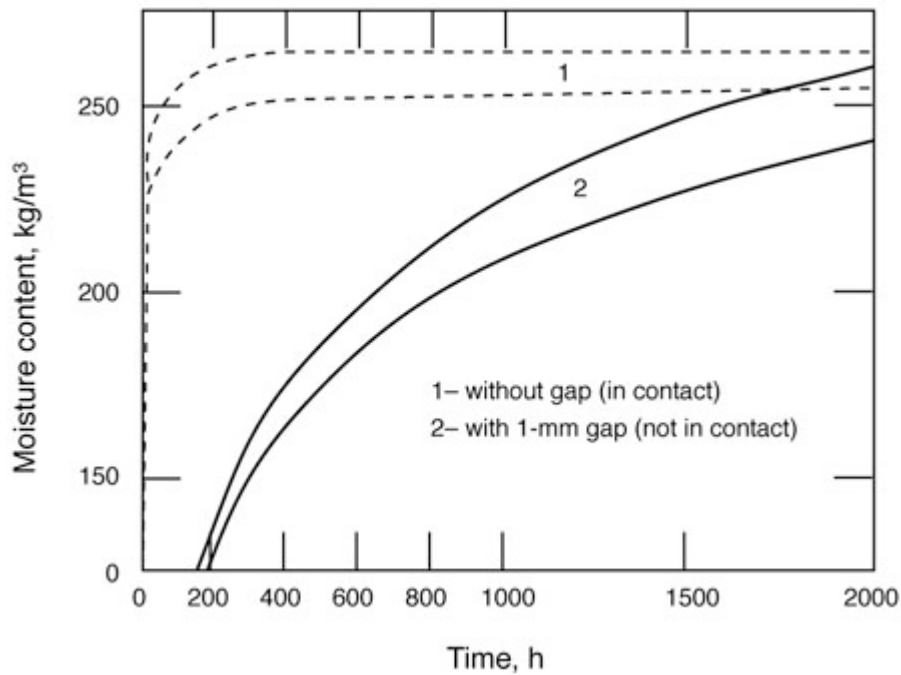

Figure 5. Moisture flow with and without gap — even a small gap (of 1 mm) can lead to a great reduction in the rate of moisture transport.

Bound water

Bound water should be intercepted with a capillary break such as a cavity or an impermeable material (Figure 5). The cavity can be partially filled as long as the fill material does not support capillary flow.¹² According to the standard for masonry construction, a cavity must be provided behind the brick veneer.¹³ When stucco is

used, provide a capillary break unless the stucco is protected from extended wetting by virtue of its climate or by building features such as overhangs.¹⁴

Continuity

Continuity is an essential feature of the second line of defence. The designer must ensure that when the cladding is attached holes are not created and must also anticipate the development of cracks and other openings as the building ages. Joints should be designed to shed water, while junctions with other components or service penetrations must be made continuous across the junction by extending the second line of defence across the rough opening to the window and door frames, for example. Design measures used to manage forces in the first line of defence should be incorporated into the second line of defence (see "[Managing Forces](#)," and Figure 6).

Dissipating Water

All water that is intercepted by the second line of defence must be dissipated to the exterior by means of drainage or evaporation, or both.

Drainage

Drainage is the only transport process with sufficient capacity to dissipate free water quickly enough to prevent deterioration from starting. All free water must be directed to the exterior through a flashed and drained cavity. A 25-mm-deep cavity is required by the standard for masonry veneer.¹⁶ In most other circumstances, a 10-mm-deep cavity will provide sufficient drainage while allowing for typical construction practices.¹ Smaller cavities provide effective drainage but the inner boundary must have increased waterresistance, since water will be retained by surface tension in a cavity less than 5 mm deep.

All horizontal surfaces that intercept the drainage cavity, e.g., windows or shelf angles, must be flashed in such a way that the flashing extends from behind the inner boundary of the second line of defence to the outside. The National Building Code requires that flashing extend upward at least 150 mm behind the inner boundary, e.g., the sheathing membrane. The flashing upstand should be higher at wall/roof intersections. Flashing should have a minimum slope of 2% towards the outside and its drip edge should extend at least 10 mm beyond the face of the wall — preferably 25 mm — to accommodate typical construction practices. CSA Standard A440.4 requires a minimum slope of 6% for exterior sill flashing. The flashing must be made of waterproof material and it must either be continuous or have sealed watertight joints. It must also have end dams to prevent water from running off the end and back into the wall.

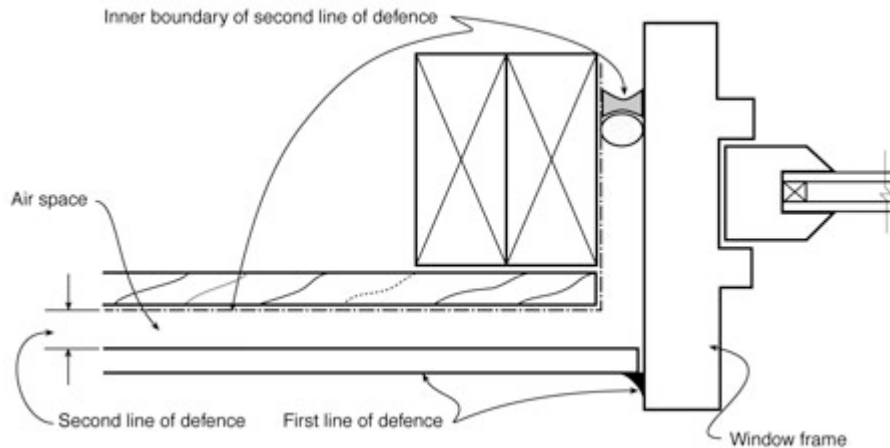

Figure 6. Design measures used to manage forces in the first line of defence should be incorporated into the second line of defence.

Size of Cavity Required for Effective Drainage^{15,16}

IRC conducted rain penetration tests on four full-scale wood-frame wall specimens with windows. Test parameters included type of cladding used for the first line of defence, and size of cavity and type of sheathing membrane used in the second line of defence. The windows were installed in flashed and drained rough openings, and sealed on the exterior. Water penetration was measured both with and without static and dynamic pressure differences across the specimens, and with several degrees of defect in the sealant, typical of those defects observed in the field.

The first three specimens were clad with 12-mm cement board with synthetic stucco finish, and installed over

- 12-mm cement board furring strips over asphalt-impregnated paper over oriented strand board (OSB), providing a 12-mm deep cavity (Figure 7).
- asphalt-impregnated paper over OSB. The space between the cement board and the paper provided the cavity (Figure 8).
- 3-mm plastic furring strips over asphalt-impregnated paper over OSB, providing a 3-mm deep cavity (Figure 9).

The fourth specimen was clad with 25-mm expanded polystyrene (EPS) with a synthetic stucco finish, and installed over a continuous layer of 3-mm plastic furring over asphalt-impregnated paper over OSB (Figure 10).

All specimens, including the one without a furred cavity, effectively drained a considerable amount of water that entered around and through the windows. However, a large amount of water was absorbed and retained in the cement board cladding in specimens 1, 2 and 3.

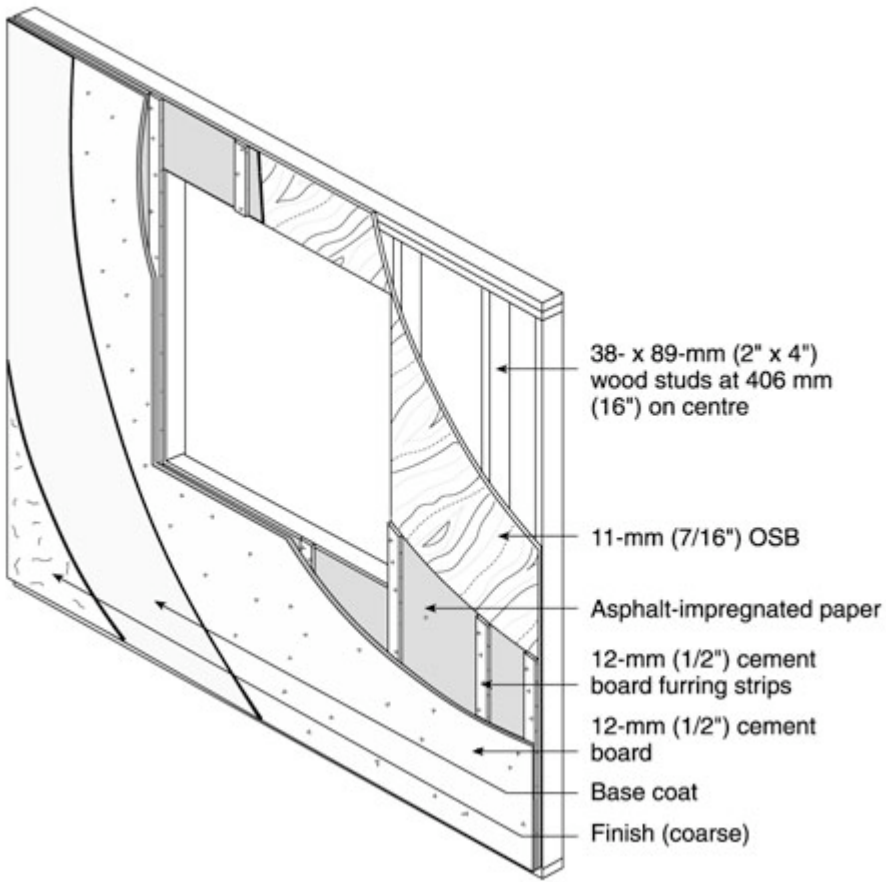

Figure 7. Specimen no. 1

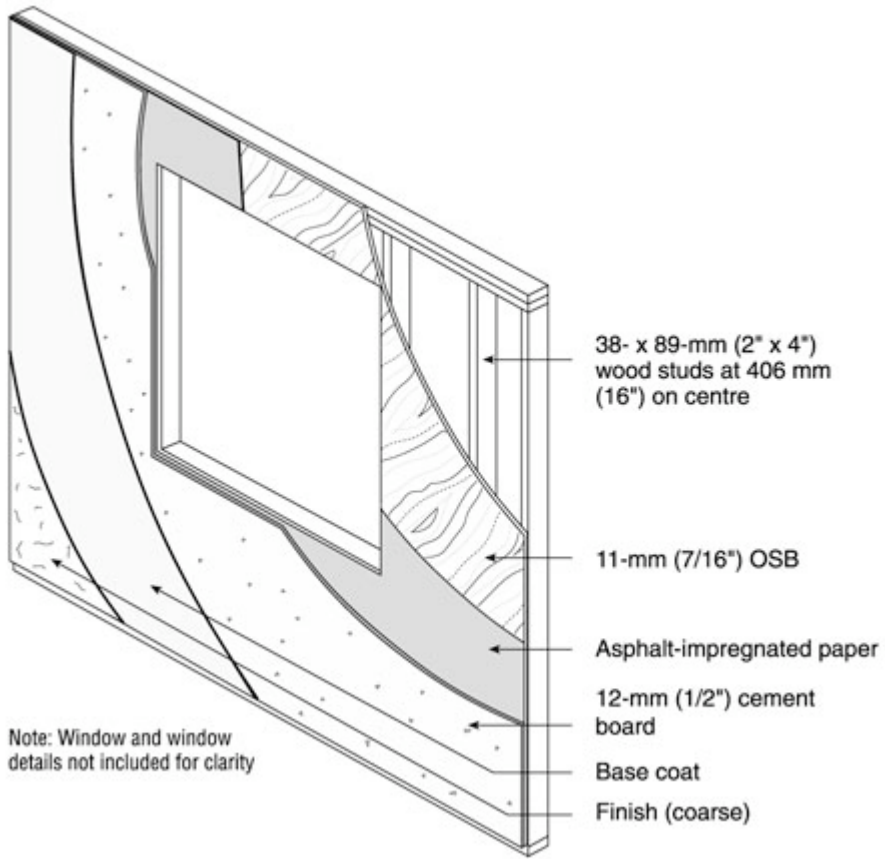

Figure 8. Specimen no. 2

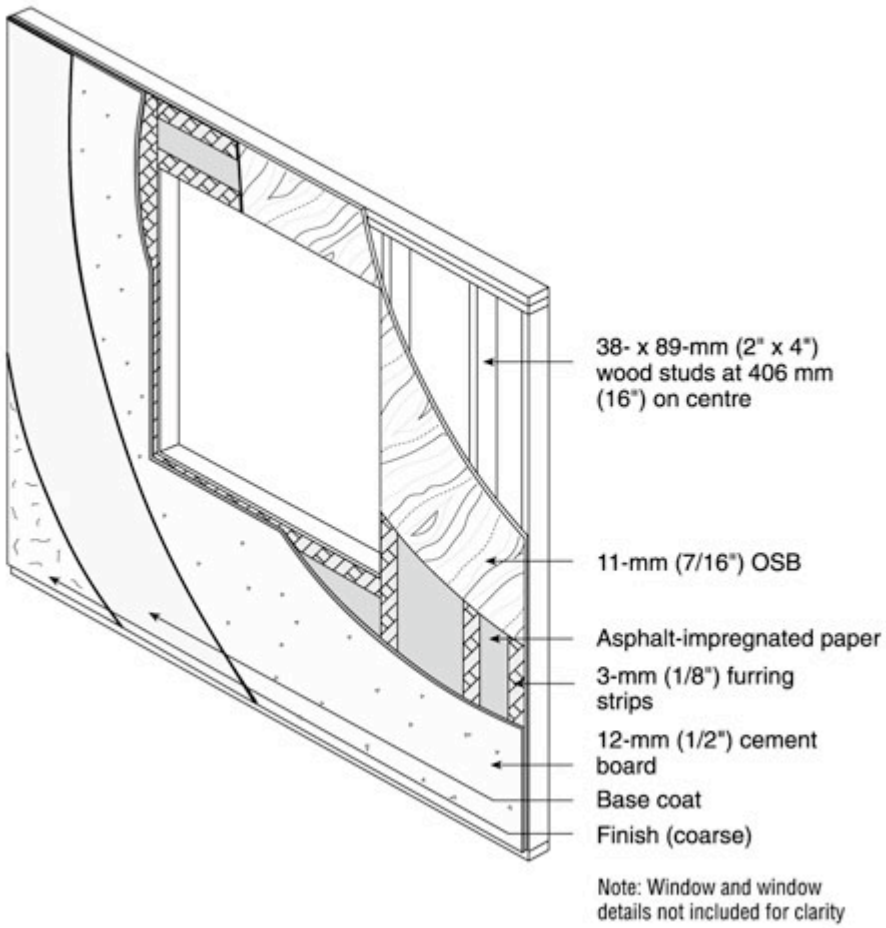

Figure 9. Specimen no. 3

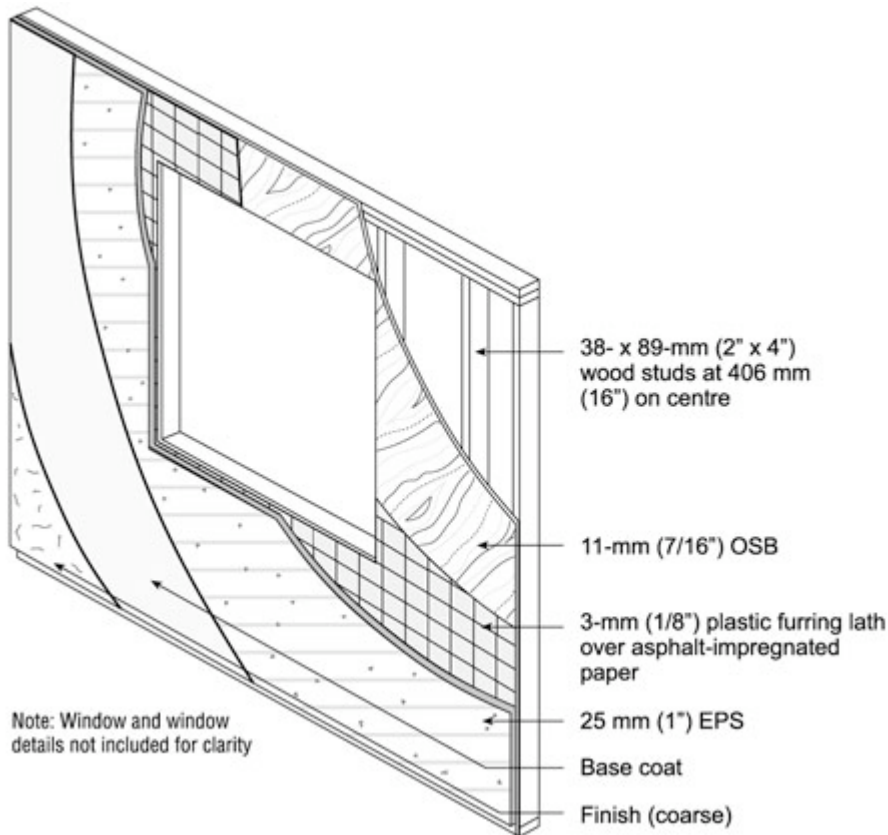

Figure 10. Specimen no. 4

Evaporation

Water that is bound in permeable materials or in channels too narrow to drain completely (usually <5 mm) must be dissipated by evaporation. Evaporation cannot be relied on if the climate is "unfavourable" — a coastal climate with high average rainfall and relative humidity falls into this category.

In a favourable climate, water "stored" in permeable cladding can evaporate from the exterior surface. Stored water may also evaporate into a cavity that serves as the capillary break in the second line of defence. It can then be dissipated to the exterior by venting — which enhances evaporation — either by vapour diffusion through holes or by airflow through holes at different heights of the cavity. Intentional holes, such as drainage holes or open shielded joints and junctions, are adequate for this purpose.

Overall Moisture Management

While rain is the biggest single source of water that must be managed by walls, interior moisture, transported through the envelope by vapour diffusion and air leakage, and heat flow must also be controlled. Failure to do so can lead to moisture overload and deterioration. Some materials and assemblies installed as part of the rainscreen may also be able to act as vapour and air barriers, and thus their location must be considered in the design. This is particularly true for the elements of the

second line of defence (the first line of defence is normally located on the outer side of a cavity that is vented to the outside). For example, insulating sheathing can control heat flow and form the inner boundary of the second line of defence if properly detailed to support the water-resistance function the inner boundary is required to perform.

Summary

The rainscreen principle specifies two complementary lines of defence to control rain penetration. For effective performance, the first line of defence must be designed to minimize rainwater passage into the wall; thus, the design of the wall assembly must

- Reduce moisture loads by including sheltering elements such as roof overhangs and by designing and detailing appropriate projecting elements such as windowsills. Rain and wind climate data serve as a basis for the moisture design load on the building.
- Minimize the number and size of holes for water transport by selecting appropriate materials and paying careful attention to the detailing of joints and junctions.
- Manage and address all forces that drive rainwater through the wall. Gravity and air pressure difference can move the largest quantities of water and hence tend to be the most significant forces. However, proper management of all forces can make the difference between success and failure.

Recognizing that some water will get past the first line of defence, rainscreen walls must incorporate a second line of defence to intercept this water and dissipate it effectively back to the exterior. Thus, the design must

- Ensure that the capacity of the second line of defence compensates for any inadequacies in the first line of defence. Traditionally, a clear cavity provided effective drainage as well as a capillary break, but today's walls, with their limited cavities, may require an inner boundary with greater water resistance than that required for the inner boundary of a clear cavity. It is also important to design junctions, protrusions and recesses with the same level of redundancy as the wall.
- Ensure that the properties of the materials used in the second line of defence are taken into account in the overall design of the wall, as these properties may affect the air and vapour permeance of the assembly.

To control rain penetration, the principles of rainscreen design must be present in all aspects of the wall design.

References

1. Chown, G.A., Poirier, G.F. and Brown, W.C. [Evolution of wall design for controlling rain penetration](#), Construction Technology Update No. 9, Institute for Research in Construction, National Research Council of Canada, 1997, 6 p.

- [2.](#) Rousseau, M.Z., Poirier, G.F. and Brown, W.C. [Pressure equalization in rainscreen wall systems](#), Construction Technology Update No. 17, Institute for Research in Construction, National Research Council of Canada, 1998, 6 p.
- [3.](#) National Building Code of Canada 1995. Canadian Commission on Building and Fire Codes, National Research Council of Canada, Ottawa, NRCC 38726, 450 p.
- [4.](#) User Selection Guide to CSA Standard A440-98, Windows. Canadian Standards Association, Etobicoke, Special Publication A440.1-98, 1998.
- [5.](#) CSA A370-94, Connectors for Masonry. Canadian Standards Association, Etobicoke, 1994.
- [6.](#) Survey of building envelope failures in the coastal climate of British Columbia, Report prepared by Morrison Hershfield Limited, Canada Mortgage and Housing Corporation, Ottawa, 1996.
- [7.](#) Robinson, G. and Baker, M.C. Winddriven rain and buildings, Division of Building Research, National Research Council of Canada, Technical paper No. 445, July 1975, NRCC 14792. 51 p.
- [8.](#) Maurenbrecher, A.H.P. [Water-shedding details improve masonry performance](#), Construction Technology Update No. 23, Institute for Research in Construction, National Research Council of Canada, 1998, 4 p.
- [9.](#) Science and Technology of Building Seals, Sealants, Glazing and Waterproofing: Fifth Volume, ASTM STP 1271, M.A. Lacasse, Ed., American Society for Testing and Materials, 1996.
- [10.](#) Ritchie, T. [Rain penetration of walls of unit masonry](#), Canadian Building Digest No. 6, Division of Building Research, National Research Council of Canada, 1960, 4 p.
- [11.](#) CAN/CGSB-51.32-M77, Sheathing Membrane, Breather Type. Canadian General Standards Board, Ottawa, 1977.
- [12.](#) Bomberg, M. Moisture flow through porous building materials, Lund Institute of Technology, Sweden, Report 52, 1974.
- [13.](#) CSA A371-94, Masonry Construction for Buildings. Canadian Standards Association, Etobicoke, 1994.
- [14.](#) Downing, A.J. The Architecture of Country Houses, Appleton and Co., New York, 1851.
- [15.](#) Brown, W.C., Ullett, J., Karagiozis, A. and Tonyan, T. Barrier EIFS clad walls: results from a moisture engineering study, Journal of Thermal Insulation and Building Envelopes, Vol. 20, 1997, pp. 206-226.
- [16.](#) Brown, W.C., Adams, P., Tonyan, T. and Ullett, J. Water management in exterior wall claddings, Journal of Thermal Insulation and Building Envelopes, Vol. 21, 1997,

pp. 23-43.

Mr. W.C. Brown is a senior research officer in the Building Envelope and Structure Program of the National Research Council's Institute for Research in Construction (IRC).

Ms. G.A. Chown is a senior technical advisor with IRC's Canadian Codes Centre.

Mr. G.F. Poirier is an evaluation officer with IRC's Canadian Construction Materials Centre.

Ms. M.Z. Rousseau is a research officer in IRC's Building Envelope and Structure Program.

© 1999

National Research Council of Canada
December 1999
ISSN 1206-1220

Date Modified: 2005-09-29



[Important Notices](#)